

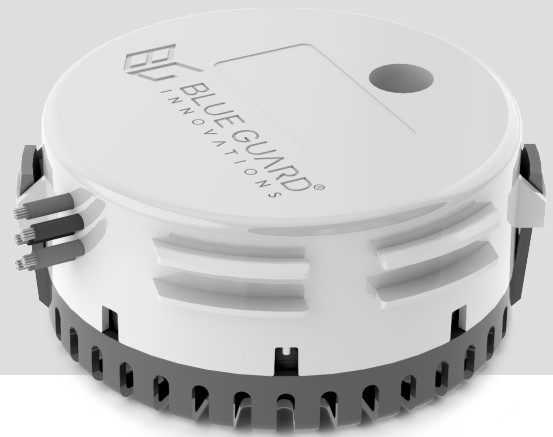

BG-One

Smart Bilge Pump Switch with Oil and Fuel Detector

USER MANUAL



PRODUCT DESCRIPTION

The BG-One is an electronic oil and fuel detector with smart bilge pump switch that uses patented technology to detect the presence of oil or fuel and integrates with the bilge pump system. Pump power is controlled by the BG-One. If oil or fuel is detected, the BG-One will prevent pumping the oil out of the bilge by turning the pump power OFF. If water or other liquid is detected, the pump will be turned ON. The BG-One is CE and ISO 8846 Marine Ignition Protection Certified, tested to ABYC-1500 standards.

There are three modes that are available in the BG-One which are configured using the *BGI Config App*, which can be downloaded from the App Store or Google Play. The App is used on a mobile device with Bluetooth to wirelessly connect to the BG-One device. The App allows selection of the operating mode and will report the input voltage level, system temperature alarm state, and pump switch state. The *BGI Config App* also allows changing the name of the device for easy identification. The App can only configure the device in the first minute that it is powered up.

INSTALLATION

The BG-One is designed for mounting near the bilge pump in a vessel. It should be mounted approximately 2" above the bilge pump outlet as shown in the *Blue Guard Installation Guide*. A mounting bracket and three #8x0.75" 316 stainless steel screws are provided to allow mounting to a vertical or horizontal structure.

If the device is mounted on the bottom of the hull of the vessel the strainer should be mounted first and then the main unit attached.

The *Blue Guard Installation Guide* shows the wiring for all supported configurations. All wiring connections are made using heavy-duty 14 gauge marine grade wire. All wiring should be done by a licensed electrician following NEC code.

INSTALL STEPS:

- 1) Locate proper mounting location for the BG-One, near the bilge pump and approximately 2" above the pump outlet.
- 2) Install mounting bracket to bulkhead using two #8x0.75" 316 stainless steel screws provided*.
- 3) Attach the BG-One into bracket with product label facing up, and wiring close to bracket.
- 4) Run wiring to BG-JBox, BG-CP, bilge pump, and battery depending on the installation chosen from the *Blue Guard Installation Guide*. Secure the wiring. It is recommended that connections to the BG-JBox be made using 14 AWG crimp spade lugs at the ends of the wires.
- 5) Apply power to the system.
- 6) Connect to the BG-One using the *BGI Config App*, set the Mode if not using Mode A (Marina). The App can be used to view the system parameters at any time, but the user must connect within one minute of powering on the BG-One device to configure it.

*The BG-One can also be mounted on the hull using three #8x0.75" 316 stainless steel screws. Mount the strainer first, then attach the BG-One into place.

SMART SWITCH MODES OF OPERATION

Mode A (Marina)

- Turns pump ON when water is detected
- Turns pump OFF when oil or fuel is detected
- Turns pump back ON when only water is detected

Mode B (Marine Sanctuary)

- Turns pump ON when water is detected
- Turns pump OFF when oil or fuel is detected
- Stays OFF until alarm and bilge is cleared (Requires power cycling of device)

Standard Mode (High Seas)

Bilge pump switch only (will turn ON or OFF for any liquid)

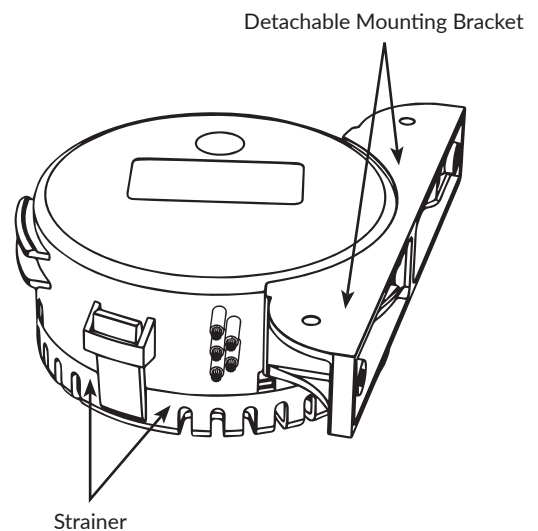

OIL DETECTION SENSITIVITY & PUMP RUN TIME

Set low, medium, or high oil detection sensitivity via the *BGI Config App*. Set the pump run time after water and oil detection via the *BGI Config App*.

Set BG-One Switch Pump Run Time*

After Water Detection Event (Normal) – Set pump run time (15-60 seconds). Factory default is 15 seconds.

After Oil Detection Event – Set pump run time after oil detection (3-15 seconds). Factory default is 3 seconds.

*After water is detected or water is detected for five seconds after oil is detected, the pump will be activated. The pump timer set above will start when the sensor detects air during pump activation. As long as the One is sensing water, the switch/pump will be on.

WIRING DESCRIPTION

Auto Power (Orange Wire) – System Power In (Can be supplied on either the Auto or Manual wire): If power is supplied to the Auto wire, the BG-One mode of operation will control the voltage on the Bilge Pump Power (Brown Wire). Supports 12 or 24 Vdc power system.

Manual Power (Red Wire) – System Power In (Can be supplied on either the Auto or Manual wire): If power is supplied to the Manual wire, the BG-One will energize the Pump Power (Brown Wire). Supports 12 or 24 Vdc power system.

Bilge Pump Power (Brown Wire) – Pump Power Output: Connect to Bilge Pump power. Note: The voltage supplied on this line is the same as the voltage provided into the BG-One on the Auto or Manual Power line. Max current sourced is 20 amps.

Alarm (Yellow Wire) – Alarm Output: Transitions from 0 Vdc to the voltage supplied on the Auto or Manual lines when oil is detected in Mode A (Marina), Mode B (Marine Sanctuary), and Standard Mode (High Seas). The output supplies up to 1 amp current. Be careful not to connect devices that have a high inrush current that exceeds 1 amp or permanent damage to the unit may occur.

Ground (Black Wire) – Ground Return: Connect to system ground per *Blue Guard Installation Guide*.

MAINTENANCE

Periodically check the base of the unit to ensure that no foreign material is stuck inside the sensor portion of the unit.

If salt has built up on the sensor portion, rinse with fresh water to clean.

When oil is detected in the bilge, the leak should be repaired and the bilge should be cleared of oil as a part of practicing prudent seamanship. After the user of the boat has cleared the bilge of oil, the bottom of the BG-One's sensor should be wiped with a soft clean cloth to remove the oil or fuel residue. If any further cleaning is required, use rubbing alcohol followed by wiping with a soft clean cloth.

FCC & IC STATEMENT

Federal Communications Commission Statement

You are cautioned that changes or modifications not expressly approved by the part responsible for compliance could void the user's authority to operate the equipment.

This device complies with Part 15 of the FCC Rules. Operation is subject to the following two conditions: 1. This device may not cause harmful interference and 2. This device must accept any interference received, including interference that may cause undesired operation of the device.

FCC RF Radiation Exposure Statement

This equipment complies with FCC radiation exposure limits set forth for an uncontrolled environment. End users must follow the specific operating instructions for satisfying RF exposure limits. This transmitter must not be collocated or operating with any other antenna or transmitter.

Industry Canada (IC)

This device complies with Industry Canada licence-exempt RSS standards. Operation is subject to the following two conditions: 1. This device may not cause interference, and 2. This device must accept any interference, including interference that may cause undesired operation of the device.

Le présent appareil est conforme aux CNR d'Industrie Canada applicables aux appareils radio exempts de licence. L'exploitation est autorisée aux deux conditions suivantes: 1. l'appareil ne doit pas produire de brouillage, et 2. l'utilisateur de l'appareil doit accepter tout brouillage radioélectrique subi, même si le brouillage est susceptible d'en compromettre le fonctionnement.

IC RF Radiation Exposure Statement

To comply with IC RF exposure requirements, this device and its antenna must not be co-located or operating in conjunction with any other antenna or transmitter.

Pour se conformer aux exigences de conformité RF canadienne l'exposition, cet appareil et son antenne ne doivent pas être co-localisés ou fonctionnant en conjonction avec une autre antenne ou transmetteur.

WARRANTY INFORMATION

Blue Guard Innovations, LLC 4909 Nautilus Ct N, Suite 121 Boulder, Colorado 80301 warrants to the original consumer purchaser that this product will be free from defects in material and workmanship, providing that the unit is not opened or otherwise abused for a period of three (3) years from the date originally purchased unless otherwise noted or sold by the manufacturer. The exclusive remedy of the consumer purchaser in the event the product is defective is to return the product to Blue Guard Innovations, LLC at the above address, freight prepaid with original sales receipt. IMPORTANT: FOR THIS WARRANTY TO BE EFFECTIVE, the product MUST BE SUPPLIED WITH PROOF OF ORIGINAL PURCHASE DATE OF THE PRODUCT. THE ACCEPTANCE BY BLUE GUARD INNOVATIONS, LLC OF ANY PRODUCT RETURNED SHALL NOT BE DEEMED AN ADMISSION THAT SUCH PRODUCT IS DEFECTIVE OR IN VIOLATION OF ANY WARRANTY. THE COMPANY RESERVES THE RIGHT TO REPAIR OR REPLACE THE PRODUCT. NO REPRESENTATIVE OR OTHER PERSON IS AUTHORIZED TO ASSUME FOR BLUE GUARD INNOVATIONS, LLC ANY ADDITIONAL LIABILITY IN CONNECTION WITH THE SALE OF ITS PRODUCTS OR TO ALTER THIS WARRANTY IN ANY WAY. IN NO EVENT WILL BLUE GUARD INNOVATIONS, LLC BE LIABLE FOR MORE THAN THE SALES PRICE OF THE PRODUCT. UNDER NO CIRCUMSTANCES WILL BLUE GUARD INNOVATIONS, LLC BE LIABLE FOR ANY LOST PROFITS, INCIDENTAL OR CONSEQUENTIAL COSTS, EXPENSES, OR DAMAGES. THE LIMITATION ON LIABILITY FOR LOST PROFITS, INCIDENTAL OR CONSEQUENTIAL COST EXPENSES OR DAMAGES SHALL SURVIVE ANY FAILURE OF ESSENTIAL PURPOSE OF THIS LIMITED WARRANTY. All wiring on the vessel shall be performed by a QUALIFIED MARINE ELECTRICIAN and in accordance with the "Fire Protection Standard for Motor Craft", NFPA No. 302. The Standards of the American Boat and Yacht Council, Inc., and the USCG Safety Standards for Boat Electrical Systems (33 CFR 183). Some states do not allow the exclusive or limitation of incidental or consequential damages, so the above limitation may not apply to you. NO EXPRESS OR LIMITED WARRANTY, INCLUDING WARRANTY OF MERCHANTABILITY AND FITNESS SHALL EXTEND FOR ANY PERIOD OF TIME GREATER THAN THREE (3) YEARS FROM THE DATE OF ORIGINAL PURCHASE OF THIS PRODUCT. Some states do not allow limitation on how long an implied warranty lasts, so the above limitation may not apply to you. CAUTION - Warranty void if seal on product is broken or product is tampered with in any way, if any electric cord is cut back more than 4 inches, if electric splices become submerged, or if product is installed contrary to instructions or warnings. Blue Guard Innovations, LLC 4909 Nautilus Ct N, Suite 121 Boulder, Colorado 80301.